

# 1. TEMPERATURE MEASUREMENT USING ELECTRICAL TECHNIQUES

Thermocouples Resistance Thermometers and Thermistors are in effect electrical temperature transducers and not direct-indicating thermometers such as mercury-in-glass devices.

In the majority of industrial and laboratory processes, the measurement point is usually remote from the indicating or controlling instrument. This may be due to necessity (e.g. an adverse environment) or convenience (e.g. centralised data acquisition). Devices are required which convert temperature into another form of signal, usually electrical and most commonly thermocouples, resistance thermometers and thermistors.

Alternative indirect techniques for sensing and measuring temperature include optical pyrometry, other non-contact (infra red), fibre-optic and quartz oscillation systems.

The use of thermocouples, resistance thermometers and thermistors requires some form of physical contact with the medium. Such contact can be immersion or surface depending on the sensor construction and the application.

## THERMOCOUPLES RESISTANCE THERMOMETERS AND THERMISTORS

**Thermocouples** essentially comprise a thermoelement (a junction of two specified dissimilar metals) and an appropriate two wire extension lead. A thermocouple operates on the basis of the junction located in the process producing a small voltage which increases with temperature. It does so on a reasonably stable and repeatable basis.

**Resistance Thermometers** utilise a precision resistor, the Ohms value of which increases with temperature (in the case of a positive temperature coefficient). Such variations are very stable and precisely repeatable.

**Thermistors** are an alternative group of temperature sensors which display a large value of temperature coefficient of resistance (usually negative, sometimes positive). They provide high sensitivity over a limited range

In practical terms, the alternative types of assembly utilise similar (in some case identical) construction but must be used in different ways depending on the application.

## Comparison of Sensor Types

	Platinum Resistance Thermometer	Thermocouple	Thermistor
Sensor	Platinum-wire wound or flat-film resistor	Thermoelement, two dissimilar metals/ alloys	Ceramic (metal oxides)
Accuracy (typical values)	0.1 to 1.0°C	0.5 to 5.0°C	0.1 to 1.5°C
Long term Stability	Excellent	Variable, Prone to ageing	Good
Temperature range	-200 to 650°C	-200 to 1750°C	-100 to 300°C
Thermal response	Wirewound – slow Film – faster 1-50 secs typical	Sheathed – slow Exposed tip – fast 0.1 to 10 secs typical	generally fast 0.05 to 2.5 secs typical
Excitation	Constant current required	None	None
Characteristic	PTC resistance	Thermovoltage	NTC resistance (some are PTC)
Linearity	Fairly linear	Most types non-linear	Exponential
Lead resistance effect	3 & 4 wire – low 2 wire – high	Short cable runs satisfactory	Low
Electrical “pick-up”	Rarely susceptible	susceptible	Not susceptible
Interface	Bridge 2,3 or 4 wire	Potentiometric input. Cold junction compensation required	2 wire resistance
Vibration effects/ shock	wirewound – not suitable Film – good	Mineral insulated types suitable	Suitable
Output/ characteristic	approx. 0.4 Ω/°C	From 10μV/°C to 40μV/°C depending on type	-4% / °C
Extension Leads	Copper	Compensating cable	Copper
Cost	Wirewound – more expensive Film – cheaper	Relatively low cost	Inexpensive to moderate

**Comments and values shown in this chart are generalised and nominal. They are not intended to be definitive but are stated for general guidance.** The information given shows average application experience, but some of the considerations can be modified by special design or selection.

These alternative temperature sensors are explained in depth in chapters 2 ,3 and 4.

## 2. THERMOCOUPLE THEORY AND PRACTICE

### 2.1. BASIC THEORY

In 1821 a German physicist named Seebeck discovered the thermoelectric effect which forms the basis of modern thermocouple technology. He observed that an electric current flows in a closed circuit of two dissimilar metals if their two junctions are at different temperatures. The thermoelectric voltage produced depends on the metals used and on the temperature relationship between the junctions. If the same temperature exists at the two junctions, the voltages produced at each junction cancel each other out and no current flows in the circuit. With different temperatures at each junction, different voltages are produced and current flows in the circuit. A thermocouple can therefore only measure temperature differences between the two junctions, a fact which dictates how a practical thermocouple can be utilised.

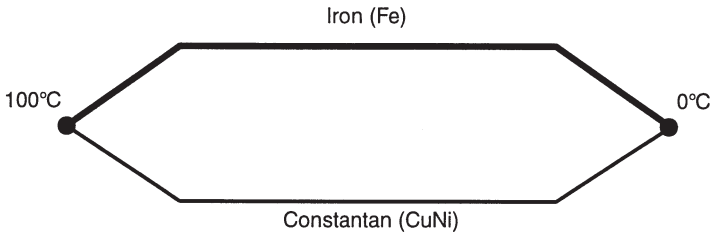

Fig 1: Thermoelement Circuit

It is important to designate each of the junctions **for practical purposes**; the **measuring junction** (often referred to as the “hot” junction) is that which is exposed to measured temperature. **The reference junction** is the other junction which is kept at a known temperature; this is often referred to as the “cold” junction. The term thermocouple refers to the complete system for producing thermal voltages and generally implies an actual assembly (i.e. a sheathed device with extension leads or terminal block.) The two conductors and associated measuring junction constitute a **thermoelement** and the individual conductors are identified as the positive or negative **leg**.

*Developments in theoretical aspects of thermoelectricity under the influence of solid-state physics has resulted in a rather different explanation of thermocouple activity. This is that the thermoelectric voltage is generated in the thermocouple wires **only in the temperature gradient existing between the “hot” and “cold” junctions** and not in the junctions themselves. Whilst this is a fundamental conceptual difference to established theory the way in which thermocouples are currently used is generally successful in practical terms. However, this explanation of thermocouple behaviour must be borne in mind when calibrating the sensor or indeed when using them for relatively high precision thermometry.*

Thermoelectric voltages are very small and at best attain a few tens of microvolts per degree Centigrade. In consequence, practical thermocouples are mainly used at elevated temperatures, above say  $100^{\circ}\text{C}$  and at depressed temperatures, below  $-50^{\circ}\text{C}$ ; however with appropriate measuring instruments they can be used at any value within their operational range. In some applications, the reference junction may be held at some temperature other than  $0^{\circ}\text{C}$ , for example in liquid gas or a heated enclosure; in any event, the measured "output" will correspond to the difference temperature between the two junctions (fig 2)

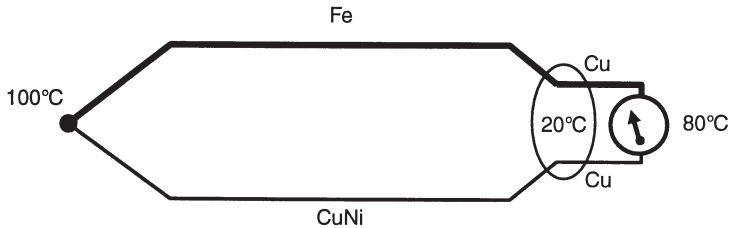

Fig 2: Thermoelement with Connecting Wires

**Note** Thermocouples are **always** formed when two different metals are connected together. For example, when the thermoelement conductors are joined to copper cable or terminals, thermal voltages can be generated at the transition (see fig. 2). In this case, the second junction can be taken as located at the connection point (assuming the two connections to be thermally common). The temperature of this connection point (**terminal temperature**) if known, allows computation of the temperature at the measuring junction. The thermal voltage resulting from the terminal temperature is added to the measured voltage and their sum corresponds to the thermal voltage against a  $0^{\circ}\text{C}$  reference.

*e.g. If the measuring junction is at  $300^{\circ}\text{C}$  and the terminal temperature is  $25^{\circ}\text{C}$ , the measured thermal voltage for the type K thermoelement (Nickel-Chromium v Nickel-Aluminium) is  $11.18\text{mV}$ . This corresponds to  $275^{\circ}\text{C}$  **difference** temperature. A positive correction of  $25^{\circ}\text{C}$  refers the temperature to  $0^{\circ}\text{C}$ ;  $300^{\circ}\text{C}$  is thus indicated.*

## 2.2. THERMOCOUPLE PRACTICE

### 2.2.1. Terminating the Thermocouple

A practical industrial or laboratory thermocouple consists of only a single (measuring) junction; the reference is always the terminal temperature. If the terminal temperature is other than controlled and stable, procedures are necessary to deal with the situation. Possible measures are:-

- Measure the terminal temperature accurately and compensate accordingly in calculating the measured value.

- b) Locate the terminals in a thermally controlled enclosure
- c) Terminate not in copper cable but use compensating or actual thermocouple wire to extend the sensor termination to the associated instrumentation (compensating cable uses low cost alloys which have similar thermoelectric properties to the actual thermoelement). On this basis, there is no thermal voltage at the thermocouples termination. The transition to copper then occurs only at the instrument terminals where the ambient temperature can be measured by the instrument; the reference junction can then be compensated for electronically.

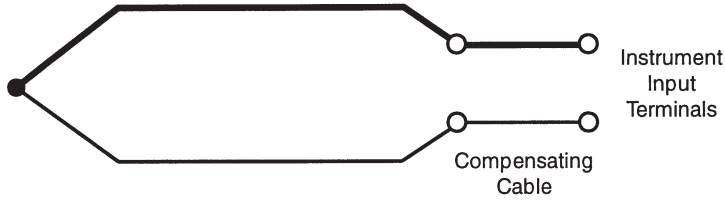

Fig 3: Thermoelement with Compensating Cable

**Note: It is essential to use only compensating or specific extension cables (these have the correct thermoelectric properties) appropriate to the thermocouple otherwise an additional thermocouple is formed at the connection point. The reference junction is formed where the compensating or extension cable is connected to a different material. The cable used must not be extended with copper or with compensating cable of a different type.**

- d) Use a **temperature transmitter** at the termination point. This is effectively bringing instrumentation close to the sensor where electronic reference junction techniques can be utilised. However, this technique is convenient and often used on plant; a transmitter produces an amplified "corrected" signal which can be sent to remote instruments via copper cable of any length.

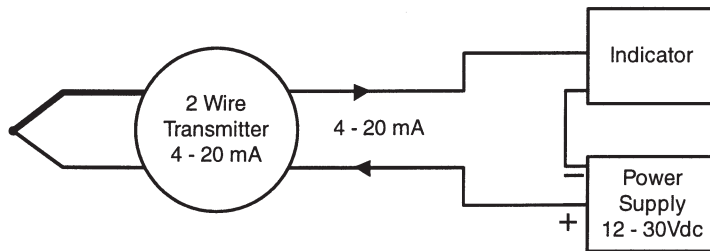

Fig 4: Temperature Transmitter – 2 Wire

### 2.2.2. External Reference Junction Techniques

Reference junction technology is usually considered as one of the main problems of any thermocouple installation. Individual instruments with thermocouples are generally provided with automatic 'cjc' (cold junction compensation). These devices sense the temperature at the point where the thermocouple is joined to the copper wiring of the instrument, and apply a corrective signal. Scanning devices such as data loggers are increasingly using this method.

**Where optimum accuracy is needed** and to accommodate multi-thermocouple installations, larger reference units are used. These are claimed to have an accuracy of  $\pm 0.1^\circ\text{C}$  or better, and allow the cables to the instrumentation to be run in copper, with no further temperature corrective device needed. The reference units are contained basically under three techniques.

- a) **The Ice Point.** This is a method of feeding the emf from the thermocouple to the measuring instrumentation via the ice-point reference which is usually operated under one of two methods, the bellows type and the temperature sensor type.

The bellows type utilises the precise volumetric increase which occurs when a known quantity of ultra pure water changes state from liquid to solid. A precision cylinder actuates expansion bellows which control power to a thermoelectric cooling device.

The temperature sensor switch type uses a metal block of high thermal conductance and mass, which is thermally insulated from ambient temperatures. The block temperature is lowered to  $0^\circ\text{C}$  by a cooling element, and maintained there by a temperature sensing device. A feature of this unit is its quick "pull down" time to  $0^\circ\text{C}$ . Special thermometers are obtainable for the checking of  $0^\circ\text{C}$  reference units, and alarm circuits that detect any movement from the zero position can be fitted. For calibration purposes the triple point cell which shows the equilibrium temperature between liquid water, ice and water vapour, and can be reproduced to extreme accuracy, is used.

The traditional Dewar flask filled with melting ice should be used with caution. Unless care and expertise are used in the making up and maintenance of the flask, comparatively large errors can result. When available a  $0^\circ\text{C}$  reference unit should be used.

- b) **The "Hot Box".** Thermocouples are calibrated in terms of emf generated by the measuring junctions relative to the reference junction at  $0^\circ\text{C}$ , referencing at another temperature therefore does present problems. However, the ability of the hot box to work at very high ambient temperatures, plus a good reliability factor has led to an increase in its usage.

The unit can consist of a solid state aluminium block thermally insulated in which the reference junctions are embedded. The block temperature is controlled by a closed loop electronic system, and a heater is used as a booster when initially switching on. This booster drops out before the reference temperature, usually between  $40^\circ\text{C}$  and  $65^\circ\text{C}$ , is reached.

- c) **Isothermal Systems.** The thermocouple junctions being referenced are contained in a block which is heavily thermally insulated. The junctions are allowed to follow the mean ambient temperature, which varies slowly. This variation is accurately sensed by electronic means, and signal is produced for the associated instrumentation. The high reliability factor of this method has favoured its use for long term monitoring.

## 2.3. THERMOCOUPLE INSTALLATION AND APPLICATION

### 2.3.1. Sheathed Thermocouples – Measuring Junctions

Many alternative sheath materials are used to protect thermoelements and some examples are indicated in a separate chapter. Additionally, three alternative tip configurations are usually offered:

- a) **An exposed (measuring) junction** is recommended for the measurement of flowing or static non-corrosive gas temperature when the greatest sensitivity and quickest response is required.



Fig 5: Exposed Junction

- b) **An insulated junction** is more suitable for corrosive media although the thermal response is slower. In some applications where more than one thermocouple connects to the associated instrumentation, insulation may be essential to avoid spurious signals occurring in the measuring circuits.

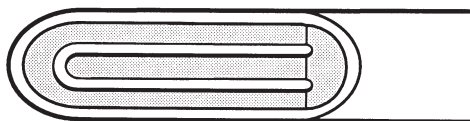

Fig 6: Insulated Junction

- c) **An earthed (grounded) junction** is also suitable for corrosive media and for high pressure applications. It provides faster response than the insulated junction and protection not afforded by the exposed junction.

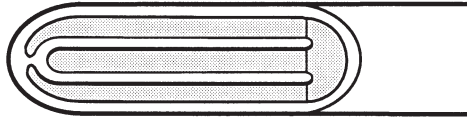

Fig 7: Earthed Junction

### 2.3.2 Connecting Thermocouples to Instruments

In industrial installations where the measuring and control instruments are located remotely from the thermocouples, compensating cable can be used between the sensor and instrument to reduce cabling costs.

Compensating cable resembles the thermoelectric characteristic of the relevant thermocouple over a limited ambient temperature range, 0° to 80°C typically. Since these cables are made from low cost materials, cost savings can be achieved on plant installations compared with running true thermocouple extension cable.

Extension cable (true thermocouple material) should be used for maximum accuracy.

#### Installation Notes:

- a) Always observe colour codes and polarity of connections for each type of thermocouple. If the current lead is used but crossed at both ends, the associated instrument will show an error equal to **twice** the temperature difference between the thermocouple termination and the instrument ambient.
- b) Avoid introducing "different" metals into the cabling, preferably use compensating colour coded connectors for the greatest accuracy, reliability and convenience of installation.
- c) Avoid subjecting compensating cable to high temperatures to avoid inaccuracies. Extension cable is superior in this respect.
- d) Do not form thermo-junctions using compensating cable; only extension cable is valid for this purpose.
- e) Use screened or braided cable connected to ground in any installation where ac pick-up or relay contact interference is likely. "Twisted pair" construction is useful in such situations.

- f) For very long cable runs, ensure that cable resistance can be tolerated by the instrumentation without resulting in measurement errors. Modern electronic instruments usually accept up to 100 Ohms or so; they will usually tolerate higher lead resistance but some error will result. Refer to relevant instrument specifications for full details.
- g) Cabling is usually available with many different types of insulation material and outer covering to suit different applications. Choose carefully in consideration of ambient temperature, the presence of moisture or water and the need for abrasion resistance.
- h) If errors or indicator anomalies occur, be sure to check the thermocouple, the cable, interconnections **and** the instrument. Many such problems are due to incorrect wiring or instrument calibration error rather than the sensor.

Interchangeability is facilitated by the use of **plug and socket interconnections**. Special connectors are available for this purpose and thermocouple alloys or compensating materials are used for the pins and receptacles to avoid spurious thermal voltages. Such connectors are usually colour coded to indicate the relevant thermocouple type and are available as "standard" size with round pins or "miniature" size with flat pins.



Fig 8: Plug and Socket Interconnections

### 2.3.3. Guide to Wire and Cable Insulation and Coverings

For maximum accuracy extension cables should be used and terminals and connectors should be of thermocouple materials to maintain continuity.

Which insulation Material?	usable temperature range	Application Notes
PVC	-10°C to 105°C	Good general purpose insulation for "light" environments. Waterproof and very flexible.
PFA (extruded)	-75°C to 250°C	Resistant to oils, acids other adverse agents and fluids. Good mechanical strength and flexibility. PTFE better for steam/elevated pressure environments
PTFE (taped & wrapped)	-75°C to 250/300°C	Resistant to oils, acids other adverse agents and fluids. Good mechanical strength and flexibility.
Glassfibre (varnished)	-60°C to 350/400°C	Good temperature range but will not prevent ingress of fluids. Fairly flexible but does not provide good mechanical protection.
High temperature glass fibre	-60°C to 700°C	Will withstand temperature up to 700°C but will not prevent ingress of fluids. Fairly flexible, not good protection against physical disturbance.
Ceramic Fibre	0 to 1000°C	Will withstand high temperature, up to 1000°C. Will not protect against fluids or physical disturbance.
Glassfibre (varnished) stainless steel overbraid	-60°C to 350/400°C	Good resistance to physical disturbance and high temperature (up to 400°C). Will not prevent ingress of fluids.

#### Single or multi-strand?

The choice is mainly determined by the application (e.g.. termination considerations and internal diameter of associated sheath). Generally, single strand wires are used for hot junctions, and multi-strand or thicker single strand for extensions of the thermocouple. The greater the effective conductor diameter, the lower the value of thermocouple loop resistance, an important consideration with long cable runs.

### 2.3.4. Performance Considerations When Connecting Thermocouples

a) Length of cable runs and loop resistance.

The resistivity of extension and compensating cables varies according to the different conductor metals; the limit to cable lengths which can be accommodated by measuring instruments therefore depends on both the thermocouple type and instrument specifications. A general rule for electronic instruments is that up to 100 Ohms loop cable resistance (i.e. total of both legs) will not result in measurement errors.

The table of loop resistances shown in the reference chapter gives values for the popular types of thermocouple. One example is that of Type K extension cable which has a combined loop resistance of 4.5 Ohms/m with 7/0.2mm conductors; in this case, 20 to 25 ( $100 \div 4.5$ ) metres is the maximum permissible cable run. The use of larger gauge wires will permit greater lengths of course.

b) Interference and Isolation.

With long runs, the cables may need to be screened and earthed at one end ( at the instrument) to minimise noise pick-up (interference) on the measuring circuit.

Alternative types of screened cable construction are available and these include the use of copper or mylar screening. Twisted pair configurations are offered and these can incorporate screening as required.

With mineral-insulated cables the use of the sheath for screening may raise problems. In certain forms the measuring point is welded to the sheath in order to reduce the response time; the screen is then connected directly to the sensor input of the instrument and is therefore ineffective. In thermocouples where the measuring point is welded to the protection tube it may be necessary to take special precautions against interference since the sheath tube can in this case act as an aerial.

Even if the measuring point is not welded to the protection tube it is inadvisable to use the sheath of a mineral-insulated thermocouple as a screen. Since it consists of non-insulated material there is a possibility with electrically heated furnaces that it can carry currents between the furnace material and the earthing point. These may result in measurement errors.

Generally, thermocouples in electrical contact with the protection tube can easily suffer interference from external voltages through voltage pick-up. In addition, two such inputs form a current loop through which the two inputs are connected together. Since such current loops form a preferred path for the introduction of interference, thermocouples should under these conditions always be **isolated** from each other, i.e. the amplifier circuits must have no electrical connection to the remaining electronics. This is already provided on most instruments intended for connection to thermocouples.

Ceramic materials used for insulating the thermocouples inside the protection tube suffer a definite loss of insulation resistance above 800 to 1000°C. The effects described can therefore appear at high temperatures even in thermocouples where the measuring junction is not welded to the protection tube. Here again full isolation is strongly recommended.

With electrically heated furnaces in the high-temperature range it is also necessary to consider that the increased conductivity of the ceramic insulating materials may cause the supply voltage to leak into the thermocouple. Here again full isolation against supply and earth potential with an insulating voltage exceeding the peak voltage of the supply (heater voltage) is essential.

The isolation of the inputs becomes specially important when electrically heated furnaces are fitted with several thermocouples which are linked to one or several instruments.

c) Thermal Voltages and terminals.

The use of brass or copper terminals in the thermocouple circuit may or may not introduce thermal voltages depending on how they are used. Interposing one or two terminations in one or both legs is permissible **provided that the temperature on both sides of the termination is exactly the same.**

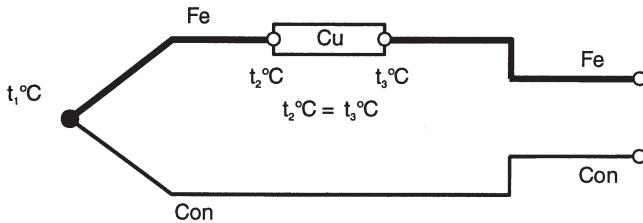

Fig 9: Using a Copper Terminal(s) in a Thermocouple Circuit

The thermal voltages produced at the junctions of Iron – Copper and Copper – Iron cancel each other at the same temperature because they are of opposite polarity, regardless of the actual temperature and of the material. This is only the case if the temperatures at both ends of the termination are the same.

With the usual two terminations, one for each core of the cable, the temperature of each can be different; it is vital though that the same temperature exists on both sides of a given termination.

Where a connection is made under circumstances of temperature variation; it is essential to use connectors free of thermal voltage effects; these are widely available.

## 2.4. DIFFERENT THERMOCOUPLE TYPES

The materials are made according to internationally accepted standards as laid down in IEC 584 1,2 which is based on the international Practical Temperature scale ITS 90. Operating temperature maxima are dependent on the conductor thickness of the thermoelements. The thermocouple types can be subdivided in 2 groups, **base metal and rare (noble) metal:**

**-200°C up to 1200°C – These thermocouples use base metals**

### Type K – Chromel-Alumel

The best known and dominant thermocouple belonging to the group chromium-nickel aluminium is type K. Its temperature range is extended (-200 up to 1100°C). Its e.m.f./ temperature curve is reasonably linear and its sensitivity is 41µV/°C

## **Type J – Iron-Constantan**

Though in thermometry the conventional type J is still popular it has less importance in Mineral Insulated form because of its limited temperature range, -200°C to +750°C. Type J is mainly still in use based on the widespread applications of old instruments calibrated for this type. Their sensitivity rises to 55µV/°C.

## **Type E – Chromel-Constantan**

Due to its high sensitivity (68µV/°C) Chromel-Constantan is mainly used in the cryogenic low temperature range (-200 up to +900°C). The fact that it is non magnetic could be a further advantage in some special applications.

## **Type N – Nicrosil-Nisil**

This thermocouple has very good thermoelectric stability, which is superior to other base metal thermocouples and has excellent resistance to high temperature oxidation.

The Nicrosil-Nisil thermocouple is ideally suited for accurate measurements in air up to 1200°C. In vacuum or controlled atmosphere, it can withstand temperatures in excess of 1200°C. Its sensitivity of 39µV/°C at 900°C is slightly lower than type K (41µV/°C). Interchangeability tolerances are the same as for type K.

## **Type T – Copper-Constantan**

This thermocouple is used less frequently. Its temperature range is limited to -200°C up to +350°C. It is however very useful in food, environmental and refrigeration applications. Tolerance class is superior to other base metal types and close tolerance versions are readily obtainable. The e.m.f./temperature curve is quite non-linear especially around 0°C and sensitivity is 42µV/°C.

## **0°C up to +1600°C – Platinum-Rhodium (Noble metal) Thermocouples**

### **Type S – Platinum rhodium 10% Rh-Platinum**

They are normally used in oxidising atmosphere up to 1600°C. Their sensitivity is between 6 and 12 µV/°C.

### **Type R – Platinum rhodium 13% Rh-Platinum**

Similar version to type S with a sensitivity between 6 and 14µV/°C.

### **Type B – Platinum rhodium 30% Rh-Platinum rhodium 6% Rh**

It allows measurements up to 1700°C. Very stable thermocouple but less sensitive in the lower range. (Output is negligible at room temperature).

Historically these thermocouples have been the basis of high temperature in spite of their high cost and their low thermoelectric power. Until the launching of the Nicrosil-Nisil thermocouples, type N, they remained the sole option for good thermoelectric stability.

*Additionally, there are specialised thermocouple types which are not described here; these include Tungsten Rhenium types, Pallaplat, Nickel Molybdenum and other Platinum Rhodium alloys.*

## 2.5. THERMOCOUPLE CONSTRUCTION

Many alternative configurations exist for thermocouple assemblies; basically two general types of construction describe most industrial thermocouples – **fabricated** and **mineral insulated**.

**Fabricated Thermocouples** are assembled using insulated thermocouple wire, sheathing (usually stainless steel) and some form of termination (extension lead, connecting head or connector for example)

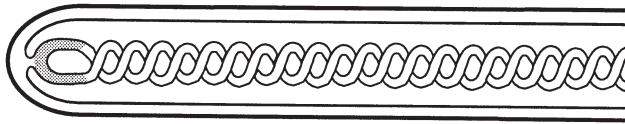

Fig 10: Fabricated Thermocouple  
Insulated, Twisted Pair Thermocouple inside Stainless Steel Sheath.  
Measuring junction earthed in this example.

**Mineral Insulated Thermocouples** consist of thermocouple wire embedded in a densely packed refractory oxide powder insulant all enclosed in a seamless, drawn metal sheath (usually stainless steel).

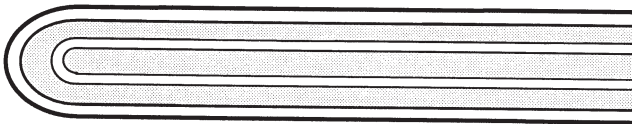

Fig 11: Mineral Insulated Thermocouple  
Thermocouple wire insulated by compressed mineral oxide powder.  
Insulated measuring junction shown in this example.

Effectively, the thermoelement, insulation and sheath are combined as a flexible cable which is available in different diameters, usually from 0.5mm to 8mm.

At one end, the cores and sheath are welded and form a “hot” junction. At the other end, the thermocouple is connected to a “transition” of extension wires, connecting head or connector.

Advantages of Mineral Insulated Thermocouples are:

- a) Small overall dimension and high flexibility which enable temperature measurement in locations with poor accessibility.
- b) Good mechanical strength
- c) Protection of the thermoelement wires against oxidation, corrosion and contamination.
- d) Fast thermal response

The mineral oxides used for insulation are highly hygroscopic and open ended cable must be effectively sealed (usually with epoxy resins) to prevent moisture take-up. A carefully prepared mineral insulated thermocouple will normally have a high value of insulation resistance (many hundreds of MOhms).

## 2.6. ACCURACY AND RESPONSE

### 2.6.1. High Accuracy Thermocouple Measurement

With thermocouple tolerances quoted at say  $\pm 2.5^\circ\text{C}$  plus other variations it would appear a poor case could be made out for high accuracy thermocouple measurement, for example in research and high industrial technology. The key to accuracy in this field lies in the careful selection of methods and materials, and the heat treatment and calibration of the thermocouples. While application conditions do alter techniques, the following factors are suggested for consideration.

1. Obtain thermocouples with insulated measuring junctions.
2. Specify “same melts” for large installations.
3. Thermocouple reference junctions should be monitored in a reference unit with an accuracy of  $\pm 0.1^\circ\text{C}$  or better.
4. Great care to be taken in running thermocouple circuitry against “pick-up” etc. with the minimum number of joins in the wiring.
5. Heat treat thermocouples to their most stable condition.
6. Calibrate thermocouples.

### 2.6.2. Thermocouple Response Times

The response time for a thermocouple is usually defined as the time taken for the thermal voltage (output) to reach 63% of maximum for the step change temperature in question. It is dependent on several parameters including the thermocouple dimension, construction, tip configuration and the nature of the medium in which the sensor is located. If the thermocouple is plunged into a medium with a high thermal capacity and heat transfer is rapid, the effective response time will be practically the same as for the thermocouple itself

(the intrinsic response time). However, if the thermal properties of the medium are poor (e.g. still air) the response time can be 100 times greater.

Sheath Outside Diameter	Types of Measuring Junction	Response Time – Seconds					
		Tip Temperature °C					
		100	250	350	430	700	850
6.0mm	insulated	3.2	4.0	4.7	5.0	6.4	16.0
6.0mm	earthed	1.6	2.0	2.3	2.5	3.15	8.0
3.0mm	insulated	1.0	1.1	1.25	1.4	1.6	4.5
3.0mm	earthed	0.4	0.46	0.5	0.56	0.65	1.8
1.5mm	insulated	0.25	0.37	0.43	0.50	0.72	1.0
1.5mm	earthed	0.14	0.17	0.185	0.195	0.22	0.8
1.0mm	insulated	0.16	0.18	0.19	0.21	0.24	0.73
1.0mm	earthed	0.07	0.09	0.11	0.12	0.16	0.6

Values shown are for a closed end sheath.

For exposed measuring junctions, divide the values shown by 10.

Fig 12: Table of Typical Thermocouple Response Times. Mineral insulated construction, closed end sheath.

Thermocouples with grounded junctions display response times some 20 to 30% faster than those with insulated junctions. Very good sensitivity is provided by fine gauge unsheathed thermocouples. With conductor diameter in the range 0.025mm to 0.81mm, response times in the region of 0.05 to 0.40 seconds can be realised.

### 2.6.3. Immersion Length

Thermocouple assemblies are “tip” sensing devices which lends them to both surface and immersion applications depending on their construction. However, immersion types must be used carefully to avoid errors due to stem conduction; this is heat flow to or from the sheath and into or away from the process which can result in a high or low reading respectively. A general rule is to immerse into the medium to a minimum of 4 times the outside diameter of the sheath; no quantitative data applies but care must be exercised in order to obtain meaningful results (e.g. have regard for furnace wall thickness and such like).

The ideal immersion depth can be achieved in practice by moving the probe into or out of the process medium incrementally; with each adjustment, note any apparent change in indicated temperature. The correct depth will result in no change in indicated temperature.

#### 2.6.4. Surface Temperature Measurement

Although thermocouple assemblies are primarily tip sensing devices, the use of protection tubes (sheaths) renders surface sensing impractical. Physically, the probe does not lend itself to surface presentation and stem conduction would cause reading errors. If a thermocouple is to be used reliably for surface sensing, it must be in either exposed, welded junction form with very small thermal mass or be housed in a construction which permits true surface contact whilst attaching to the surface. Locating a thermocouple on a surface can be achieved in various ways including the use of an adhesive patch, a washer and stud, a magnet for ferrous metals and pipe clips. Examples of surface sensing thermocouples are shown below:

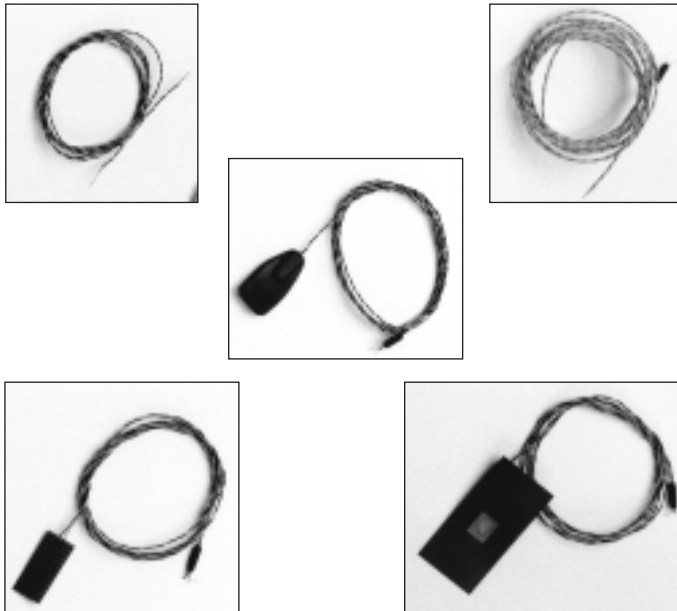

Fig 13: Thermocouples for Surface Temperature Sensing

If it is possible to provide lagging (thermal insulation) around the sensor assembly, accuracy will be improved. Thermocouples are ideal for such applications since their measuring junctions have a very small thermal mass and are physically small.

# 3. RESISTANCE THERMOMETER THEORY AND PRACTICE

## 3.1. BASIC THEORY

The electrical conductivity of a metal depends on the movement of electrons through its crystal lattice. Due to thermal excitation, the electrical resistance of a conductor varies according to its temperature and this forms the basic principles of resistance thermometry. The effect is most commonly exhibited as an increase in resistance with increasing temperature, a **positive temperature coefficient of resistance**.

When utilising this effect for temperature measurement, a large value of temperature coefficient (the greatest possible change of resistance with temperature) is ideal; however, stability of the characteristic over the short and long term is vital if practical use is to be made of the conductor in question. The relationship between the temperature and the electrical resistance is usually non-linear and described by a higher order polynomial:

$$R(t) = R_0 (1 + A:t + B:t^2 + C:t^3 + \dots)$$

where  $R_0$  is the nominal resistance at a specified temperature. The number of higher order terms considered is a function of the required accuracy of measurement. The coefficients A, B and C etc. depend on the conductor material and basically define the temperature -resistance relationship.

Materials most commonly utilised for resistance thermometers are Platinum, Copper and Nickel. However, Platinum is the most dominant material internationally

### Platinum Sensing Resistors

Platinum sensing resistors are available with alternative  $R_0$  values, for example 10, 25 and 100 Ohms. A working form of resistance thermometer sensor is defined in IEC and DIN specifications and this forms the basis of most industrial and laboratory electrical thermometers. The **platinum sensing resistor**, Pt100 to IEC 60751 is dominant in Europe and in many other parts of the world. Its advantages include chemical stability, relative ease of manufacture, the availability of wire in a highly pure form and excellent reproducibility of its electrical characteristic. The result is a truly interchangeable sensing resistor which is widely commercially available at a reasonable cost.

This specification includes the standard variation of resistance with temperature, the nominal value with the corresponding reference temperature, and the permitted tolerances. The specified temperature range extends from -200 to 961.78°C. The series of reference values is split into two parts: -200 to 0°C and 0 to 961.78°C.

The first temperature range is covered by a third-order polynomial

$$R(t) = R_0(1 + A.t + B.t^2 + C. [t - 100°C] .t^3)$$

For the range 0 to 850°C there is a second-order polynomial

$$R(t) = R_0(1 + A.t + B.t^2)$$

The coefficients are as follows:

$$A = 3.9083 \times 10^{-3} \cdot ^\circ\text{C}^{-1}$$

$$B = -5.775 \times 10^{-7} \cdot ^\circ\text{C}^{-2}$$

$$C = -4.183 \times 10^{-12} \cdot ^\circ\text{C}^{-4}$$

The value  $R_0$  is referred to as **nominal value** or **nominal resistance** and is the resistance at 0°C. According to IEC 751 the nominal value is defined as 100.00 Ohm, and this is referred to as a **Pt100** resistor. Multiples of this value are also used; resistance sensors of 500 and 1000 Ohm are available to provide higher sensitivity, i.e. a larger change of resistance with temperature.

The resistance changes are approximately:

0.4 Ω/°C for the Pt100

2.0 Ω/°C for the Pt500

4.0Ω/°C for the Pt 1000

An additional parameter defined by the standard specification is the mean temperature coefficient between 0 and 100°C. It represents the mean resistance change referred to the nominal resistance at 0°C:

$$\alpha = \frac{R_{100} - R_0}{R_0 \times 100^\circ\text{C}} = 3.850 \times 10^{-3} \text{ } ^\circ\text{C}^{-1}$$

**Note:** For exact calculation use  $\alpha = 0.00385055^\circ\text{C}^{-1}$

$R_{100}$  is the resistance at 100°C,  $R_0$  at 0°C. The resistance change over the range 0°C to 100°C is referred to as the **Fundamental Interval**.

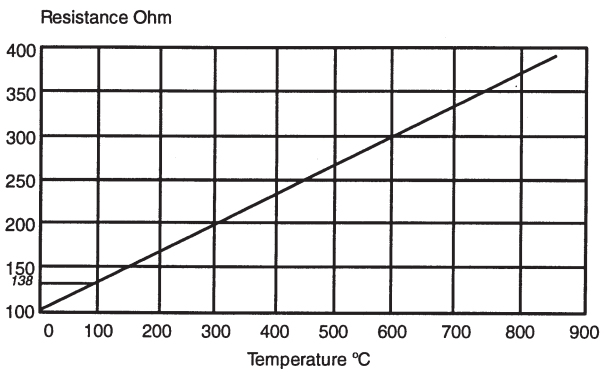

Fig 14: Resistance/Temperature Characteristics of Pt100

The very high accuracy demanded of primary standard resistance thermometers requires the use of a more pure form of platinum for the sensing resistor. This results in different  $R_0$  and alpha values. Conversely, the platinum used for Pt100 versions is “doped” to achieve the required  $R_0$  and Alpha values.

### 3.2. ADOPTION OF Pt100 THERMOMETERS

The practical range of Pt100 based thermometers extends from -200°C to 650°C although special versions are available from up to 962°C. Their use has in part taken over from thermocouples in many applications for a variety of reasons:

- a) Installation is simplified since special cabling and cold junction considerations are not relevant. Similarly, instrumentation considerations are less complex in terms of input configuration and enhanced stability.
- b) Instrumentation developments have resulted in high accuracy, high resolution and high stability performance from lower cost indicators and controllers; such accuracy can be better exploited by the use of superior temperature sensors.
- c) The availability of a growing range of sensing resistor configurations has greatly expanded the scope of applications; such configurations include miniature, flat-film fast response versions in addition to the established wirewound types with alternative tolerance bands.

The usable maximum temperature of the sensing resistor is dependent on the type of sheath material used to provide protection. Those using stainless steel should not exceed 500°C because of contamination effects. Nickel and Quartz are alternative choices allowing higher operating temperatures.

*Refer to section 1 of this handbook for comparisons between Resistance Thermometers and Thermocouples.*

### 3.3. RESISTANCE THERMOMETER PRACTICE

#### 3.3.1. Terminating the Resistance Thermometer

Fundamentally, every sensing resistor is a two wire device. When terminating the resistor with extension wires, a decision must be made as to whether a 2,3 or 4 wire arrangement is required for measurement purposes.

In the sensing resistor, the electrical resistance varies with temperature. Temperature is measured indirectly by reading the voltage drop across the sensing resistor in the presence of a constant current flowing through it using Ohm's Law:  $V = R.I$

The measuring current should be as small as possible to minimise sensor heating; a maximum of around 1mA is regarded as acceptable for practical purposes. This would produce a 0.1V drop in a Pt100 sensing resistor at 0°C; the voltage dropped which varies with temperature is then measured by the associated circuitry.

The interconnection between the Pt100 and the associated input circuit must be compatible with both and the use of 2,3 or 4 wires must be specified accordingly.

It is essential that in any resistance thermometer the resistance value of the external leadwires be taken into account, and if this value affects the required accuracy of the thermometer, its effect should be minimised.

This is usually accomplished by connecting the leadwires into the modified **WHEATSTONE BRIDGE** circuit in the measuring instrumentation. The leadwires can be 2,3 or 4 in number, often dependant upon the requirements of the instrumentation and/or the overall accuracy required. Two leads are adequate for some industrial applications, three leads compensating for lead resistance improves accuracy, and for the highest accuracy requirements four leads are required, in a current/voltage measuring mode. Typical bridge circuits for 2, 3 and 4 lead thermometers are shown below:

Fig 15: Practical Bridge Circuits for 2, 3 and 4 Wire Thermometers.

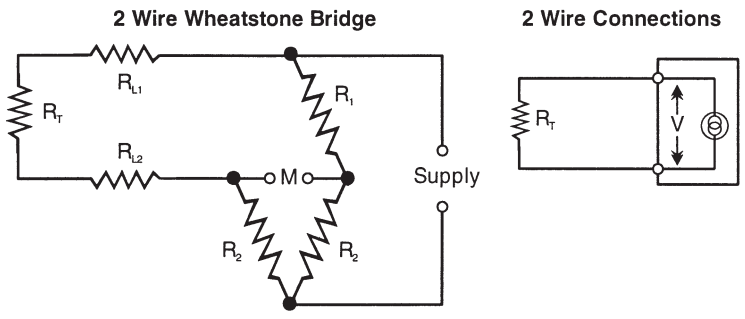

The meter reads  $R_T + (R_{L1} + R_{L2})$ .  $R_{L1}, R_{L2}$  are lead resistances.

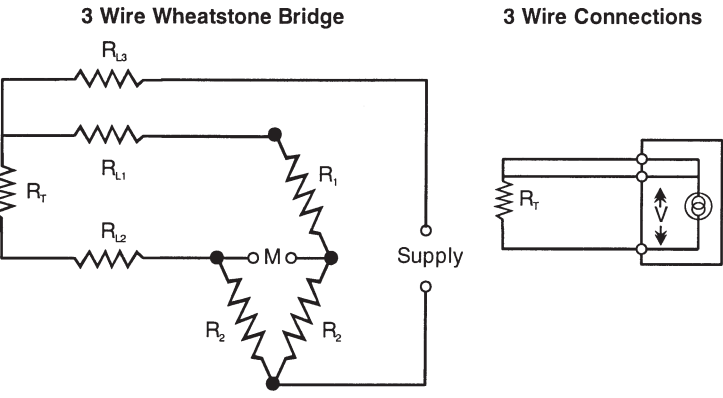

One lead resistance is included in each of the two arms of the bridge. The errors reduce to  $R_{L1} - R_{L2}$ .

#### 4 Wire Compensated Wheatstone Bridge

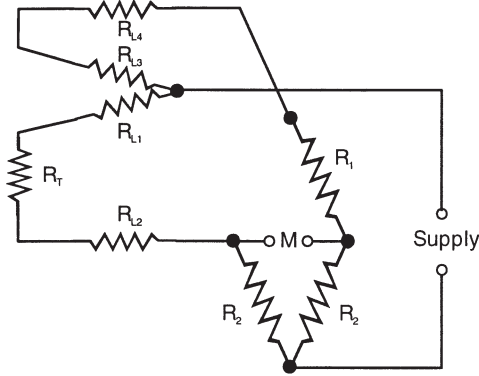

#### 4 Wire Connections

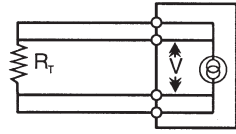

$R_{L3}, R_{L4}$  appear in one arm of the bridge and  $R_{L1}, R_{L2}$  in the other.  
Errors are  $R_{L1} + R_{L2} - R_{L3} - R_{L4}$ .

The connection between the thermometer assembly and the instrumentation is made with standard electrical cable with copper conductors in 2,3 or 4 core construction. The cabling introduces electrical resistance which is placed in series with the resistance thermometer. **The two resistances are therefore cumulative and could be interpreted as an increased temperature if the lead resistance is not allowed for.** The longer and/or the smaller the diameter of the cable, the greater the lead resistance will be and the measurement errors could be appreciable. In the case of a **2 wire connection**, little can be done about this problem and some measurement error will result according to the cabling and input circuit arrangement.

For this reason, a **2 wire arrangement is not recommended**. If it is essential to use only 2 wires, ensure that the largest possible diameter of conductors is specified and that the length of cable is minimised to keep cable resistance to as low a value as possible.

**The use of 3 wires**, when dictated either by probe construction or by the input termination of the measuring instrument, will allow for a good level of lead resistance compensation. **However the compensation technique is based on the assumption that the resistance of all three leads is identical** and that they all reside at the same ambient temperature; this is not always the case. Cable manufacturers often specify a tolerance of up to  $\pm 15\%$  in conductor resistance for each core making accurate compensation impossible. Additional errors may result from contact resistance when terminating each of the 3 wires. A 3 wire system can not therefore be relied upon for total accuracy.

**Optimum accuracy is therefore achieved with a 4 wire configuration.** The Pt100 measuring current is obtained through the supply. The voltage drop across the sensing resistor is picked off by the measurement wires. If the measurement circuit has a very high input impedance, lead resistance and connection contact resistances have negligible effect. The voltage drop thus obtained is independent of the connecting wire resistivity. In practice, the transition from the 2 wires of the Pt100 to the extension wires may not occur precisely at the element itself but may involve a short 2 wire extension for reasons of physical construction; such an arrangement can introduce some error but this is usually insignificant.

*Note: The wiring configuration (2,3, or 4 wire) of the thermometer must be compatible with the input to the associated instrument.*

### 3.3.2. Transmitters

The problems of the 2 or 3 wire configuration as described can be resolved in large part by using a 4-20mA transmitter. If the transmitter is located close to the Pt100, often in the terminal head of the thermometer, then the amplified “temperature” signal is transmitted to the remote instrumentation. Cable resistance effects are then not applicable other than those due to the relatively short leadwires between the sensor and transmitter.

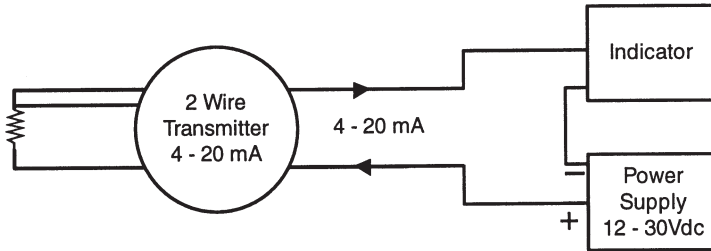

Fig 16: Temperature Transmitter – 2 Wire Loop. Input Pt100, 3 Wire

Most transmitters use a 3 wire input connection and therefore provide compensation for lead resistance.

## 3.4. RESISTANCE THERMOMETER INSTALLATION AND APPLICATION

### 3.4.1. Sheathed Resistance Thermometers – Pt100 Sensing Resistors

A variety of sheath materials is used to house and protect the alternative types of sensing resistors; sheath materials are described in a separate chapter.

The resistance element is produced in one of two forms, either wire-wound or metal film. Metal film resistors consist of a platinum layer on a ceramic substrate; the coil of a wire wound version is fused into ceramic or glass.

### a) Wire – wound resistors.

The construction of the wire wound platinum detector uses a large proportion of manual labour, with a high degree of training and skill. The careful selection of all components is vital, as are good working conditions. Complete compatibility between metal, ceramic and glass when used, together with the connecting leads is essential, and most important, strain must be eliminated. Various methods of detector construction are employed to meet the requirements of differing applications. The unsupported “bird cage” construction is used for temperature standards, and the partially supported construction is used where a compromise is acceptable between primary standards and use in industrial applications. Other constructional methods include the totally supported construction which can normally withstand vibration levels to 100g, and the coated wire construction where the wire is covered with an insulating medium such as varnish. The maximum operating range of the latter method is limited by the wire coating to usually around 250°C.

Of the differing methods of construction described, the partially supported construction is the most suited for industrial applications where high accuracy, reliability and long term stability are required. The wire is wound into a small spiral, and inserted into axial holes in a high purity alumina rod. A small quantity of glass adhesive is applied to these holes, which after firing secures a part of each wire into the alumina. Detectors have been produced by this method as thin as 0.9mm diameter and as short as 6mm with a resistance accuracy of  $\pm 0.01\%$ . A host of other sizes and shapes are produced. The internal leads of a detector assembly should be constructed of materials dictated by the temperature the assembly will have to withstand. Up to 150°C and 300°C silver leads are preferred, from 300°C to 500°C nickel leads are considered best although the resistance tends to be high, and above 550°C noble metal leads prove most satisfactory.



Fig 17: Pt100 Resistors

### b) Metal Film Resistors

Metal film Pt resistors take the form of a thin (1 micron) film of platinum on a ceramic substrate. The film is laser trimmed to have a precise  $R_0$  value and then encapsulated in glass for protection.

A wide range of styles and dimensions are produced to allow for different applications. Such sensors have fast thermal response and their small thermal mass minimises intrusion in the media being tested. Such sensors are known variously as flat film, thin film or chip sensors.

Thermoelements and resistance thermometer sensing resistors alike normally require protection from environmental conditions and, depending on the application would normally be housed in a suitable sheath material if immersion is required. Alternative housings are used for non-immersion use such as in surface or air sensing.

### 3.4.2. Connecting Resistance Thermometers to Instruments

Unlike thermocouples, resistance thermometers do not require special cable and standard electrical wires with copper conductors should be used. The heavier the gauge of the conductors, the less the impact is on errors due to lead resistance effects as described. Typically 7/0.2mm or 14/0.2mm conductors are specified with insulation chosen to suit a particular application. Refer to "Terminating the Resistance Thermometer on page 27 for details of the different wiring configurations (2,3 or 4 wire).

#### Recommended Colour Codes BS EN 60751:1996

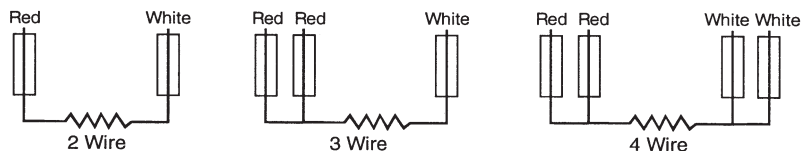

#### Installation Notes:

- Always observe colour codes and terminal designations; the wiring configuration of the thermometer must match that of the instrument input arrangement.
- Avoid introducing "different" metals into the cabling; preferably use copper connecting blocks or colour coded (or other dedicated) connectors for the greater accuracy, reliability and convenience of installation.
- Use screened or braided cable connected to ground in any installation where ac pick-up or relay contact interference is likely.
- For very long cable runs, ensure that cable resistance can be tolerated by the instrumentation without resulting in measurement errors. Modern electronic instruments usually accept up to 100 Ohms or so for 3 or 4 wire inputs. Refer to the relevant instrument specifications for full details.
- Cabling is usually available with many different types of insulation material and outer covering to suit different applications. Choose carefully in consideration of ambient temperature, the presence of moisture or water and the need for abrasion resistance.

- f) If errors occur, be sure to check the sensor, the cable, interconnections **and** the instrument. Many such problems are due to incorrect wiring or instrument calibration error rather than the sensor.

Interchangeability is facilitated by the use of plug and socket interconnections. Special connectors are available for this purpose.

### Guide to Cable Insulation and Coverings

Which insulation Material?	usable temperature range	Application Notes
PVC	-10°C to 105°C	Good general purpose insulation for "light" environments. Waterproof and very flexible.
PFA (extruded)	-75°C to 250°C	Resistant to oils, acids other adverse agents and fluids. Good mechanical strength and flexibility. PTFE better for steam/elevated pressure environments
PTFE (taped & wrapped)	-75°C to 250/300°C	Resistant to oils, acids other adverse agents and fluids. Good mechanical strength and flexibility.
Glassfibre (varnished)	-60°C to 350/400°C	Good temperature range but will not prevent ingress of fluids. Fairly flexible but does not provide good mechanical protection.
High temperature glass fibre	-60°C to 700°C	Will withstand temperature up to 700°C but will not prevent ingress of fluids. Fairly flexible, not good protection against physical disturbance.
Ceramic Fibre	0 to 1000°C	Will withstand high temperature, up to 1000°C. Will not protect against fluids or physical disturbance.
Glassfibre (varnished) stainless steel overbraid	-60°C to 350/400°C	Good resistance to physical disturbance and high temperature (up to 400°C). Will not prevent ingress of fluids.

#### 3.4.4. Performance Considerations When Using Resistance Thermometers

There are various considerations appropriate to achieving good performance from resistance thermometer sensors:

- a) Length of cable runs and loop resistance – Refer to Installation Notes
- b) Interference and Isolation

With long cable runs, the cables may need to be screened and earthed at one end (at the instrument) to minimise noise pick-up (interference) on the measuring circuit.

Poor insulation is manifested as a reduction in the indicated temperature, often as a result of moisture ingress into the probe or wiring.

### c) Self-heating

In order to measure the voltage dropped across the sensing resistor, a current must be passed through it. The measuring current produces dissipation which generates heat in the sensor. This results in an increased temperature indication. There are many aspects to the effects of self-heating but generally it is necessary to minimise the current flow as much as possible; 1mA or less is usually acceptable. The choice of current value must take into account the  $R_s$  value of the sensing resistor since  $\text{dissipation} = I^2R$ .

If the sensor is immersed in flowing liquid or gas, the effect is reduced because of more rapid heat removal. Conversely, in still gas for example, the effect may be significant. The self-heating coefficient  $E$  is expressed as:

$$E = \Delta t / (R - I^2)$$

where  $\Delta t$  = (indicated temperature) – (temperature of the medium)

$R$  = Pt resistance

$I$  = measurement current

### d) Stem conduction

This is the mechanism by which heat is conducted from or to the process medium by the probe itself; an apparent reduction or increase respectively in measured temperature results. The immersion depth (the length of that part of the probe which is directly in contact with the medium) must be such as to ensure that the "sensing" length is exceeded (double the sensing length is recommended). Small immersion depths result in a large temperature gradient between the sensor and the surroundings which results in a large heat flow.

The ideal immersion depth can be achieved in practice by moving the probe into or out of the process medium incrementally; with each adjustment, note any apparent change in indicated temperature. The correct depth will result in no change in indicated temperature.

For calibration purposes 150 to 300mm immersion is required depending on the probe construction.

The use of thermowells increases the thermal resistance to the actual sensor; heat also flows to the outside through the thermowell material. Direct measurements are preferable for good response and accuracy but may be mechanically undesirable.

Low flow rates or stationary media result in reduced heat transfer to the thermometer; maximum flow rate locations are necessary for more accurate measurement.

### 3.4.5. Surface Temperature Measurement

Resistance thermometers are mainly stem sensing devices with a finite sensing length and as such are best suited to immersion use. However, certain types of sensing resistors can be applied to surface sensing when suitably housed. Thin film devices and miniature wire-wound elements can be used in a surface contact assembly such as those shown below. In such cases, the sensing devices must be held in close contact with the surface whilst being thermally insulated from the surrounding medium. Rubber and PTFE bodies are often utilised for such assemblies. Locating the device on a surface can be achieved in various ways including the use of an adhesive patch and pipe clips. If it is possible to provide lagging (thermal insulation) around the sensor assembly, accuracy will be improved.



Fig 18: Self Adhesive Patch Pt100 Sensor for Surface Temperature Sensing

### 3.4.6. High Accuracy Measurement

Assuming a 3 or 4 wire connection, and the use of a class B sensing resistor (refer to page 83 for tolerance details), a standard thermometer assembly will provide an accuracy of around  $0.5^{\circ}\text{C}$  between  $0^{\circ}\text{C}$  and  $100^{\circ}\text{C}$ . Considerable improvement on this figure can be achieved by various means including the use of closer tolerance sensors. Reference to the tolerance chart on page 83 will indicate "accuracies" of the standard Class B and Class A devices. However, tolerances of  $\frac{1}{3}$ ,  $\frac{1}{5}$  and  $\frac{1}{10}$  of the Class B values are available with wirewound and other resistors and these allow for higher precision of measurement. It is important to note that these tolerances are rarely achieved in practice due to stress and strain in handling and assembly, extension lead wire effects and thermal considerations. However, the closer tolerances do provide more precise basic accuracy platforms. Practical overall accuracy of around  $0.15^{\circ}\text{C}$  can be achieved between  $0^{\circ}\text{C}$  and  $100^{\circ}\text{C}$  if a  $\frac{1}{10}$ DIN sensor is used.

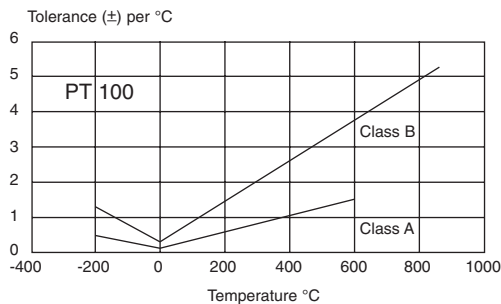

Fig 19: Pt100 Tolerances

System (probe and instrument) accuracy can be optimised by means of calibration and certification which identifies overall measurement errors; such calibrations are usually carried out to international standards.

High precision resistance thermometers are available for laboratory use and accuracies of a few millidegrees can be achieved using such devices. These may use different alpha values and must be calibrated at fixed points. Nominal 10, 25 and special 100 Ohm  $R_0$  versions may be used.

## 4. NTC THERMISTORS & INFRARED (NON-CONTACT) SENSORS

The **NTC Thermistor** is an alternative to the Platinum resistance thermometer; the name derives from “thermal resistor” and defines a metallic oxide which displays a high negative **temperature coefficient** of resistance. This compares with the small positive coefficient of say Platinum used for the Pt100 sensor. The temperature-resistance characteristic of the thermistor is up to 100 times greater than that of the alternative resistance thermometer and provides high sensitivity over a limited temperature range.

PTC (Positive Temperature Coefficient) versions are also available but their use is much less common than the popular NTC types.

High resistance thermistors, greater than 100kOhms are used for high temperatures (150 to 300°C); devices up to 100kOhms are used for the range 75 to 150°C. Devices below 1kOhm are suitable for lower temperatures, -75 to +75°C.

Thermistors provide a low cost alternative to the Pt100 although the temperature range is limited; interchangeability and accuracy place them between Pt100 and thermocouple alternatives. Since their resistance value is relatively high, a simple 2 wire connection is used.

### 4.1. RESISTANCE / TEMPERATURE CHARACTERISTIC

The electrical resistance of a NTC (Negative Temperature Coefficient) Thermistor, decreases non-linearly with increasing temperature.

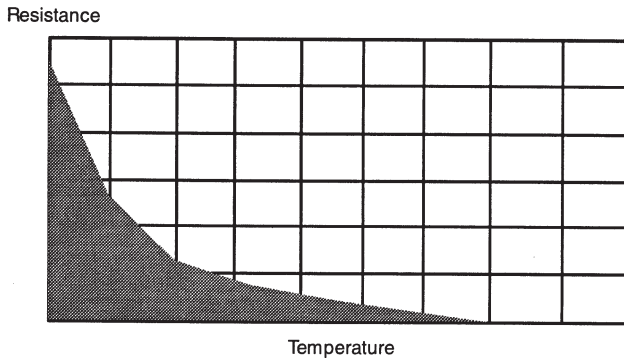

Fig 20: Resistance/Temperature Characteristics of NTC Thermistor

The amount of change per degree Celcius (C) is defined by either the BETA VALUE (material constant), or the ALPHA COEFFICIENT ( resistance temperature coefficient).

The Beta Value is defined by:

$$\text{Beta} = \frac{1}{\frac{1}{T_1} - \frac{1}{T_2}} \times \log_n \frac{R_1}{R_2}$$

where T1 and T2 are two specified temperatures, usually 273.15K (0°C) and 323.15K (50°C), and R1 over R2 is the ratio of the measured resistance at the two specified temperatures. Beta is expressed in degrees Kelvin.

**The Alpha Coefficient is defined by:**

$$\alpha = \frac{1}{R_T} \times \frac{dR}{dT}$$

where T is specified temperature in degrees K, R is resistance at specified temperature T. Alpha value is usually expressed in % per °C. There is a direct relationship between the Alpha Coefficient and the Beta Value.

The larger the Alpha or Beta Value, the greater the change in resistance per °C, (the greater the sensitivity). Within the thermistor industry, a thermistor material system is usually identified by specifying the Alpha coefficient, Beta Value, or the ratio between the resistance at two specified temperatures (typically, RO/R50, R25/R125, RO/R25, R70/R25, or RO/R70).

#### 4.1.1. Electrical Resistivity

Electrical Resistivity (Ohm-cm) is one electrical characteristic of different materials. It is equal to the resistance to current flow of a centimetre cube of a particular material, when the current is applied to two parallel faces. It is defined by the following equation:

$$R = \rho \frac{l}{A}$$

where R is resistance, l is length of a uniform conductor, A is cross-sectional area, and ρ is resistivity .

When comparing different thermistor materials, the material with the larger Alpha or Beta value will generally have the larger resistivity.

Material resistivity is an important consideration when choosing the proper thermistor for an application. The material must be chosen such that a thermistor chip of a specified resistance value will not be too large or too small for a particular application. Thermistor materials are available with a variety of resistivity values. The resistance of an NTC thermistor is determined by material resistivity and physical dimensions. Required resistance value is usually specified at 25°C.

### 4.1.2. Self-heating

At low measuring current levels, the power dissipated by a thermistor is small and is of little consequence to measurement accuracy. Increased current results in increased dissipation causing the sensor to heat up; an increased temperature is indicated resulting in measurement errors.

#### General

Probe construction and connection to instruments are as for resistance thermometers but only a 2 wire arrangement is used (lead resistances will be very small compared with sensor resistance).

## 4.2 INFRARED TEMPERATURE MEASUREMENT

### 4.2.1 Principles of Infrared Sensing

Energy is radiated by all objects having a temperature greater than absolute zero ( $-273^{\circ}\text{C}$ ). The energy level increases as the temperature of the object rises.

Therefore by measuring the level of the energy radiated by any object, the temperature of that object can be obtained. For this purpose, energy in the infrared band is used (wavelengths of between 0.5 micron and 20 micron are observed in practice). Emissivity has to be taken in to account when evaluating the temperature using infra-red radiation (described below).

### 4.2.2. Methods of Measurement

The two most common methods of sensing and measuring temperature on a non-contact, infrared basis are:

- a) Optical pyrometry
- b) Non-contact thermocouple

Optical pyrometry uses comparison techniques to measure temperature ; non-contact thermocouple techniques provide an accurate, convenient and relatively inexpensive alternative.



Fig 20a: Infrared Digital Thermometer

**Infrared thermocouples** are passive devices which provide a “true” thermocouple output signal appropriate to the type specified (usually type J or type K). Such sensors can therefore be directly connected to the thermocouple input of an instrument but, unlike the standard thermocouple provide convenient, non-intrusive, remote temperature sensing. This approach is usually inexpensive, especially when compared with optical systems. The compact dimensions of these devices makes them as convenient as a thermocouple to install in industrial processes or to use in experiments; hand held sensors are also available.

The detection method used by many infrared thermocouples is similar in principle to that of optical systems, the **thermopile**. A thermopile consists of an array of thermocouple junctions arranged in a high density series matrix; heat energy radiated from the object results in an “amplified” output from the sensor (i.e. a multi-thermojunction signal as opposed to that of a single junction).

The output is scaled to correspond to that of the specified thermocouple type (e.g. approx.  $40\mu\text{V}/^\circ\text{C}$  for type K over a limited and reasonably linear range).

Since the sensor receives only infrared radiation energy, the rules of thermal radiation apply and such things as non-linearity and emissivity must be considered.

**Linearity:** Over a restricted temperature range, the sensor output is sufficiently linear to produce a signal which emulates that of the thermocouple with reasonable accuracy; an accuracy of around 2% can be achieved for a type K non-contact sensor over the range  $50^\circ\text{C}$  to  $650^\circ\text{C}$  for example.

**Emissivity:** Emissivity is a parameter which defines how much radiation an object emits at a given temperature compared with that of a **black body** at the same temperature. A **black body** has an emissivity of 1.0; there is no surface reflection and 100% surface emission.

*The emissivity of a surface is the percentage of the surface which emits; the remaining percentage of the surface reflects. The percentage though, is expressed as a coefficient hence 100% equivalent to 1.0. All values of emissivity fall between 0.0 and 1.0.*

For accurate measurement of different materials, ideally, the emissivity should be taken into account and correction applied. Simple instruments may not allow for this but more sophisticated alternatives incorporate emissivity adjustment.

Other considerations include sensor to object distance / target area considerations and the possible need for sensor cooling in high temperature applications.